

BUTTERFLY VALVE

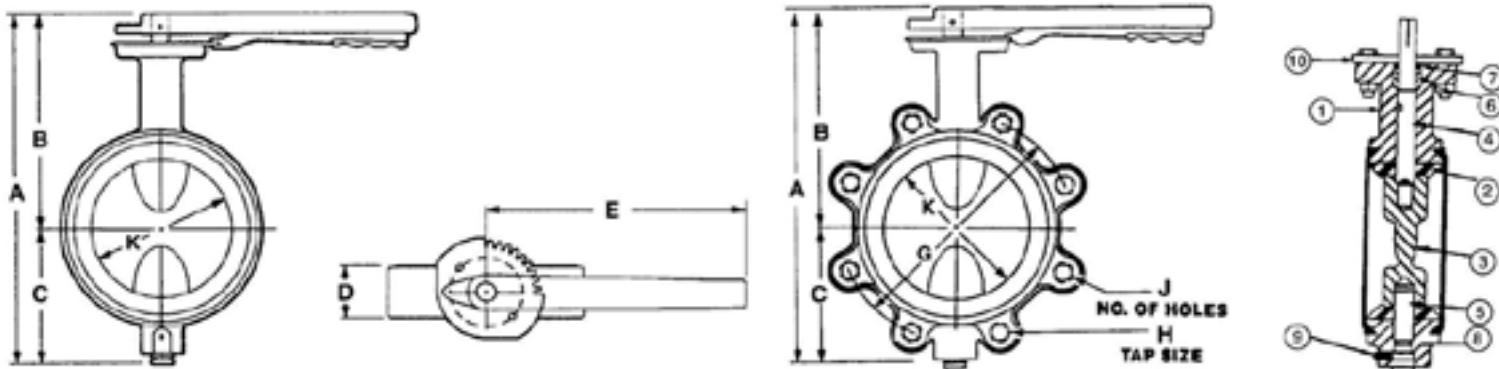

BILL OF MATERIAL/SPECIFICATION		
Part #	ITEM DESCRIPTION	MATERIAL SPECIFICATION
1	Body Lug/Wafer Cast Iron	ASTM A-126-B
2	Liner—EPDM	ASTM D-2000
3	Disc—Aluminum Bronze	ASTM A-148
4	Upper Stem	AISI 420
5	Lower Stem	AISI 420
6	Upper Stem Bearing	Oil Impregnated Bronze
7	Upper Stem O-Ring	EPDM
8	Lower Stem O-Ring	EPDM
9	Lower Stem Set Screw	ASTM A-582
10	Position Plate 10 Pos./In/Pos.	Carbon Steel

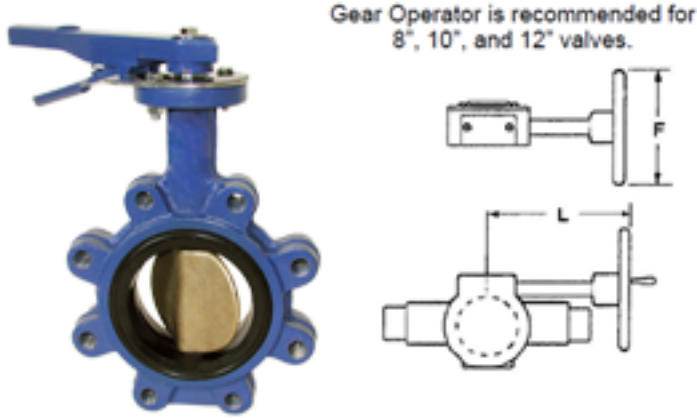

Gear Operator is recommended for 8", 10", and 12" valves.

DESIGN DATA Temp. 250° F
 Pressure 200 PSI WOG
 Dead End 140 PSI (Lug Only)

WAFER AND LUG

DIMENSION TABLE (inches)

Qty	Size		A	B	C	D	E	F	G	H	J	K	L	Weight	
	Inch	MM												Lug	Wafer
	2"	50	10-5/8	7-1/2	3-1/8	1-5/8	10-3/8	6	4-3/4	5/8-11 UNC	4	2	5-1/4	11	10
	2-1/2	65	11-1/2	8	3-1/2	1-3/4	10-3/8	6	5-1/2	5/8-11 UNC	4	2-1/2	5-1/4	12	11-1/2
	3	75	12	8-3/8	3-5/8	1-3/4	10-3/8	6	6	5/8-11 UNC	4	3	5-1/4	12-1/2	12
	4	100	13-1/2	9	4-1/2	2	10-3/8	6	7-1/2	5/8-11 UNC	8	4	5-1/4	20	16
	5	125	15	9-5/8	5-3/8	2-1/8	10-3/8	6	8-1/2	3/4-10 UNC	8	5	5-1/4	26	22
	6	150	15-1/2	10	5-1/2	2-1/4	10-3/8	6	9-1/2	3/4-10 UNC	8	6	5-1/4	30	24
	8	200	17-1/2	10-3/4	6-3/4	2-1/4	10-3/8	12	11-3/4	3/4-10 UNC	8	8	9-1/2	70	57
	10	250	20-1/2	12-3/4	7-3/4	2-3/4	10-3/8	12	14-1/4	7/8-9 UNC	12	10	9-1/2	97	78
	12	300	23-3/4	14-12	9-1/4	3-1/8	10-3/8	12	17	7/8-9 UNC	12	12	10-1/8	129	107

CUSTOMER _____

PROJECT _____

ENGINEER _____

ARCHITECT _____

PRO. OR P.O. NO. _____



DESCRIPTION:

MODEL VBFLY-I

WAFER AND LUG STYLE IRON BUTTERFLY VALVES

DRAWING BY: _____ DATE: 1/1/13

DRAWING NO. VBFLY-I